

Hjulstjernerne støbes af Staal.

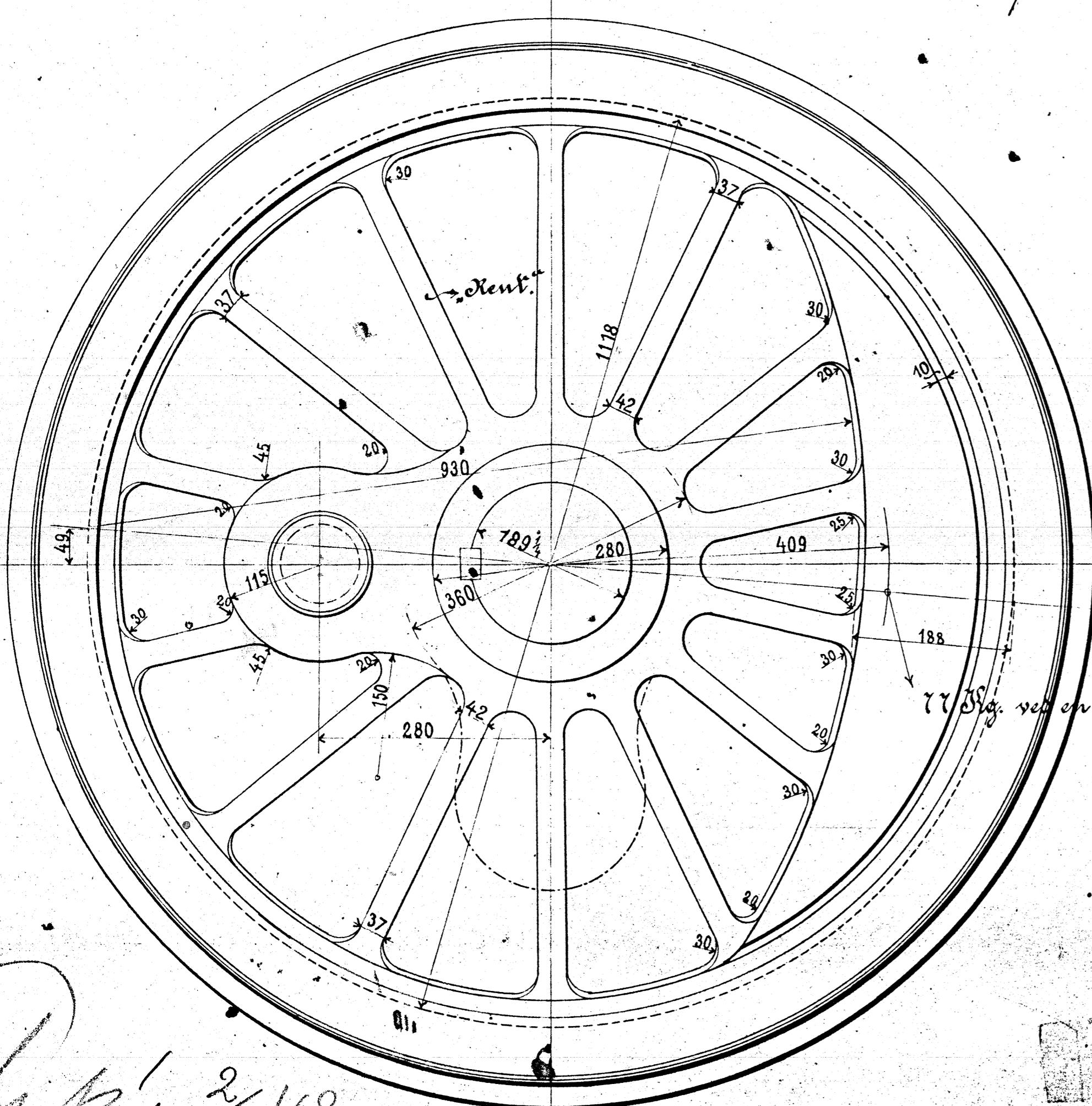

1 Stk.

3:1 sand Størrelse. Indvendig Side af Navet.

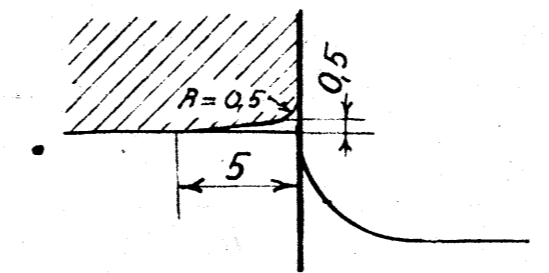

Skibe i Akselen.

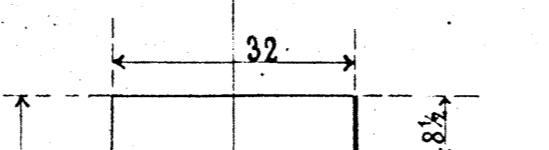

Skibe i Drivhjuletappen.

2 Stk.

1:5. sand Størrelse.

For åbent stangbæredning lukket 12.09-12.09.13

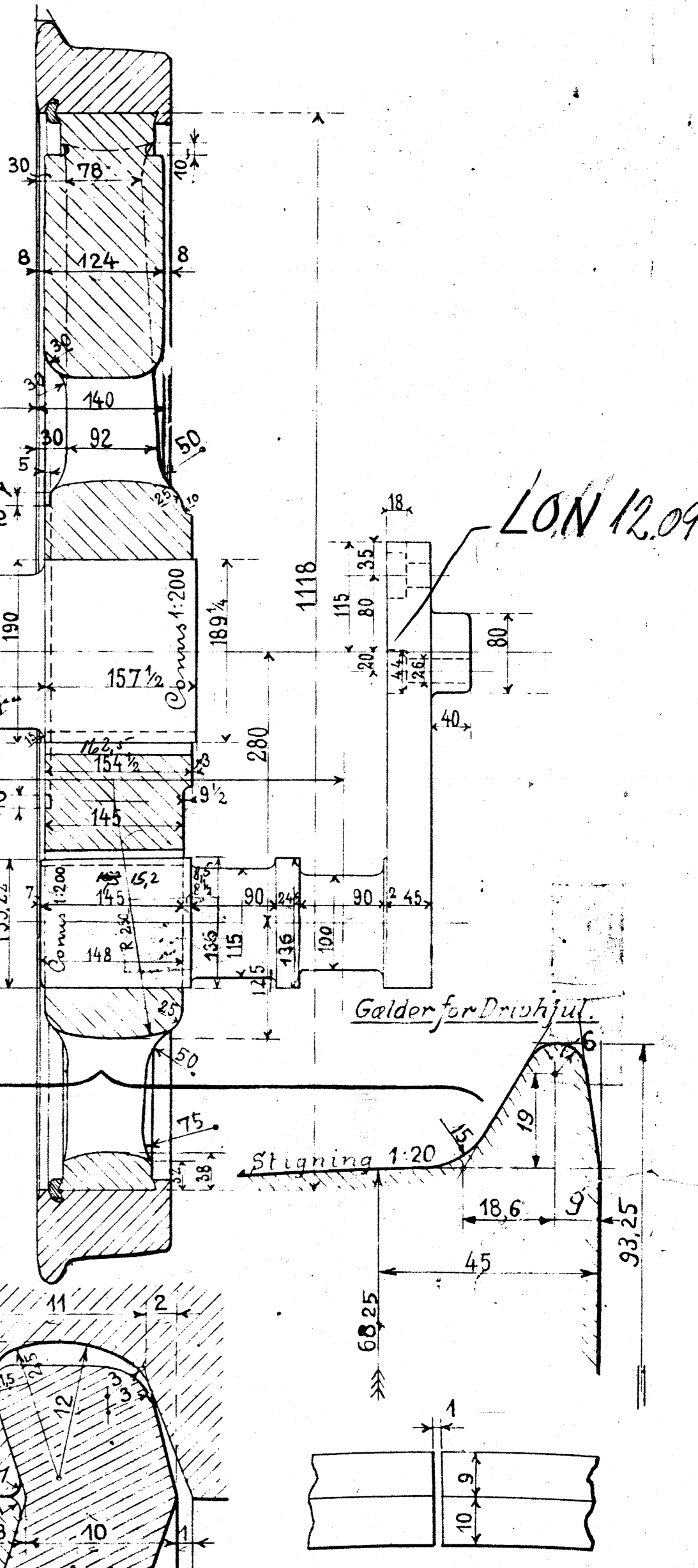
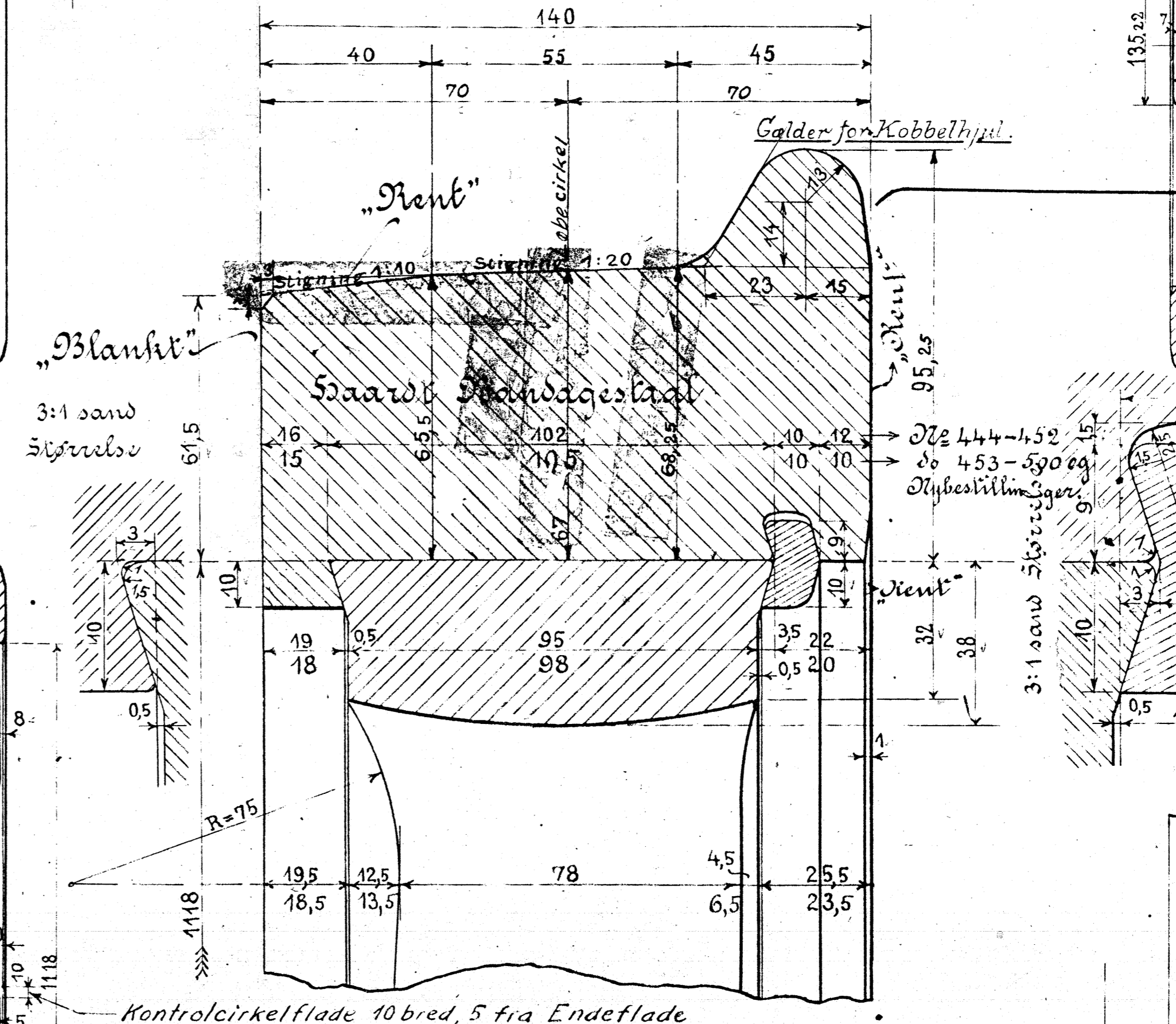
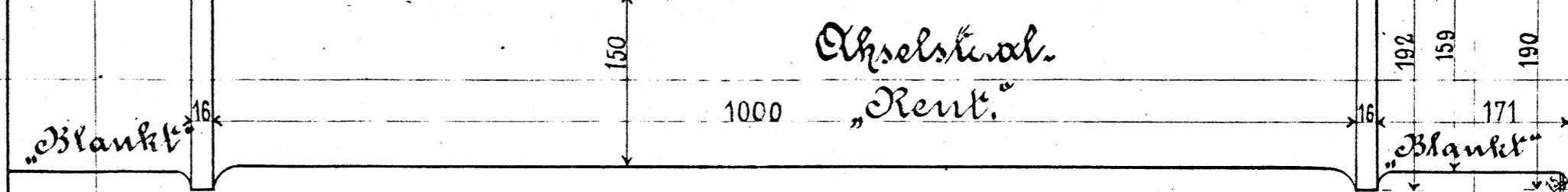
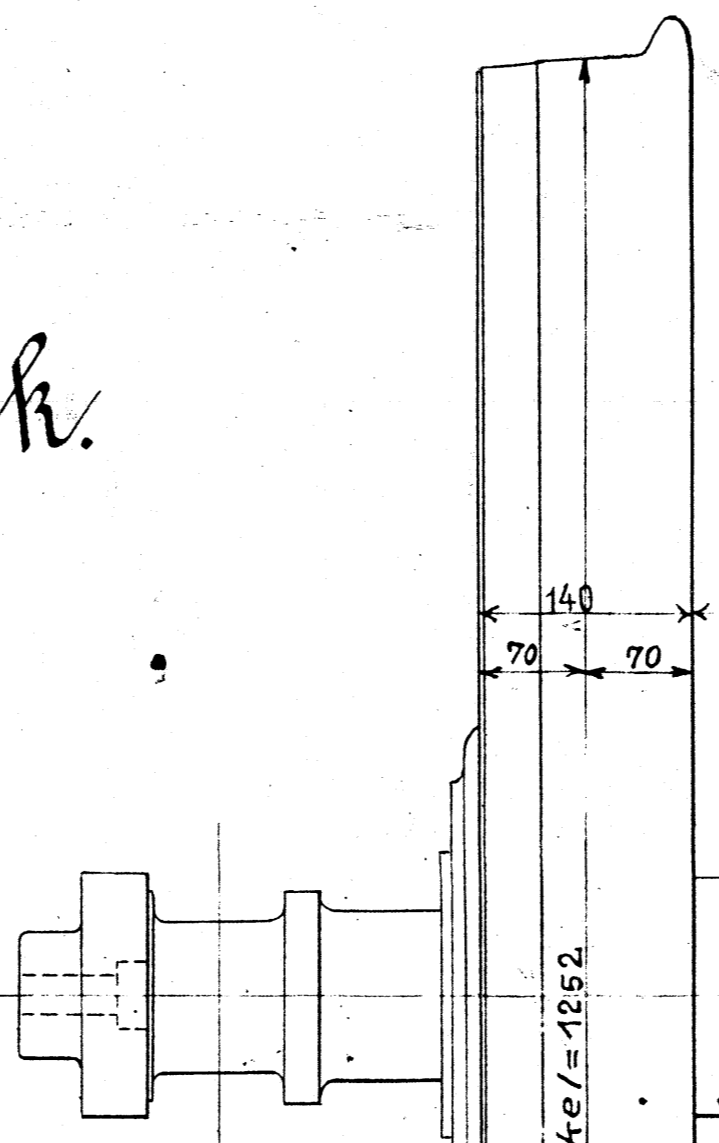
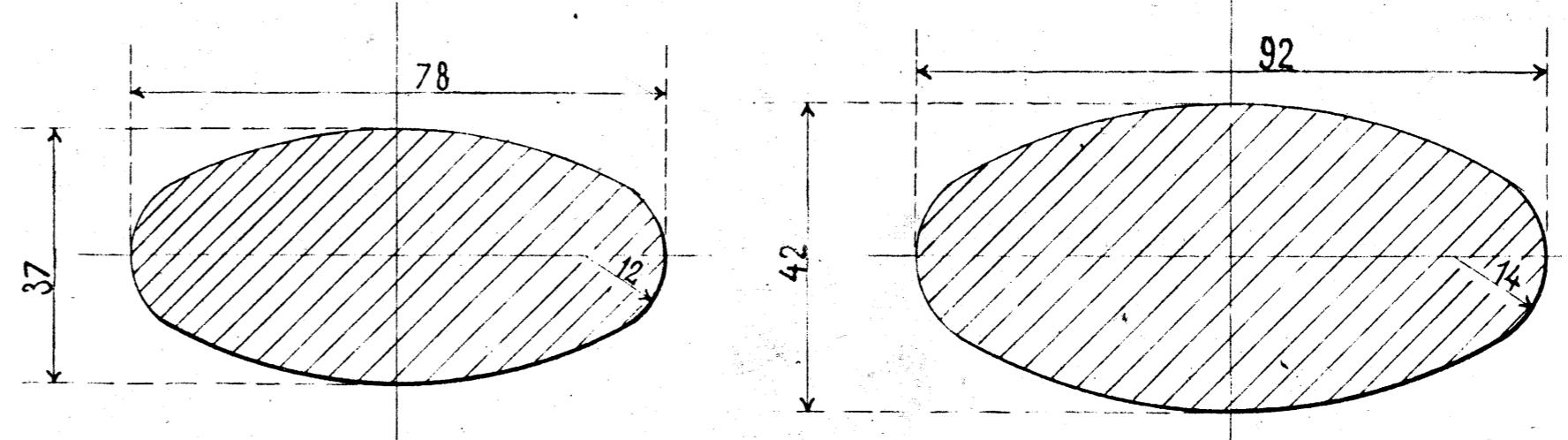

LON 12.09-8

13. G. 61-64 og 453-500 have hjul uden Sprængringe. " " 444-452 " " med " "

Danske Statsbaner - Maskinafdelingen.
Driv- og Kobbelhjul
 til
 Loko: Litra F_{II}.

København, Januar 1898.

Maskinfabrik

Forandringer		Dato	Mærke
Løbercelles Diam.	rettet til lige Tol.	25/28	H.H.E.
Hul til Aksel reifet	indvendig	18/33	V.S.
Gennemboing i Tapper	bortfaldet	21/34	V.S.
Kontrolflade	tegnet ind	7/35	V.S.
Maal paa den smalle Hjulflange	ændret	2/42	E.S.
LON for Tappe indt.		1/50	E.S.

Rev. 23.11.98. *Handwritten signature and date*

Handwritten numbers and initials at the bottom right.